

## Sx2 Power-Switch

### Bosch-cablekit for Sx2 Tuning-Dongle

## Installation manual

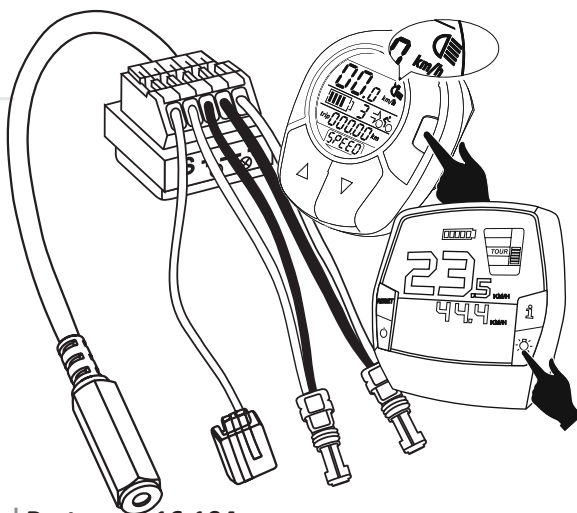

Part.no.: 16.104

Document: Sx2\_Power\_Switch\_Bosch\_cablekit\_ma-  
nual\_B02\_V01\_EN

Creation date: 06 / 2014

1

Please read these operation instructions carefully before use and keep it for further reference.



### IMPORTANT!

Drivers of Pedelecs who occasionally stay outside the scope of the Road Traffic Licensing Regulations e.g. on private property, cordoned racetracks or abroad resp. have a red insurance licence plate and who wish to test the drive's performance, the inserted Sx2 Tuning-Dongle offers a technical chance to do so.

If you unplug the Sx2 Tuning-Dongle, your eBike will be reset to its original state.

### Note to the German Road Traffic Licensing Regulations (StVZO) and disclaimer:

We expressly point out that the Sx2 Tuning-Dongle may only be used on private, enclosed areas and designated routes.

The use of the Sx2 Tuning-Dongle leads to a speed manipulation of your Pedelec – which is not allowed on roads to which the Road Traffic Licensing Regulations apply.

No liability is assumed for any current or future damage to persons and/or objects resulting from the improper installation or use of the Sx2 Tuning-Dongle. Use exclusively at own risk!

The use either/or application of the Sx2 Tuning-Dongle

2

le may limit or void the warranty of your eBike as the installation of the dongle constitutes a modification resp. manipulation of the bike.

This note has been generated automatically and is valid without signature.

Date of creation and version: November 2012

### Description of the features:

- Between 12 and 25 km per hour, the speed is divided by 2 and indicates exactly half speed. Thus, the BOSCH driving modes can be preserved.
- Its pluggable and compact design allows the driving on public roads to which the Road Traffic Licensing Regulations apply – simply by pulling the Sx2 Tuning-Dongle.
- For protection purposes, the Sx2 Tuning-Dongle is molded maintenance-free and does not require a battery
- Enhancements such as turning-off while driving or cable extensions with trading goods make the Sx2 Tuning-Dongle highly flexible

### Before Installation:

With the Sx2 Power Switch Bosch cable kit, the Dongle can be switched on or off via the Bosch HMI and Intuvia Display. The original Bosch lightning plugs for both front and rear lights are already included in the scope of delivery. The cable kit consists of the switching electronics, a terminal block to which the sensor and both lightning cables are connected to with the original Bosch

3

lightening plugs and the 3.5 mm jack socket connecting lead for the Sx2 Tuning-Dongle.

**IMPORTANT!** The lightning function must be unlocked by the manufacturer or a specialist dealer. Both lightning cables must be connected – as otherwise, an error message appears on the display. The cable kit will be installed in the engine’s terminal compartment.

For this mode of installation, the stone chip cover of the engine’s terminal compartment has to be removed to get to the connections.

If you do not have the right tools, the Sx2 Tuning-Dongle should be installed by a good eBike dealer.

### Scope of Delivery/Accessories:

- 1 terminal block (4) power switch with terminals and connecting cables for the 3.5 mm jack socket
- 2 original Bosch lightning plugs for front and rear light (3)
- 1 gel blade connector for the speed sensor plus a substitution blade connector
- 1 installation manual Sx2 power switch Bosch cable kit.

Configuration Terminal Block:

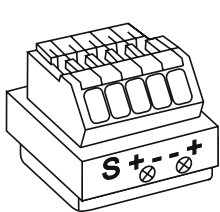

<b>S</b>	Speed sensor + wire (red)
<b>+⊗</b>	Positive pole lightning plug (red)
<b>-⊗</b>	Negative pole lightning plug (black)

4

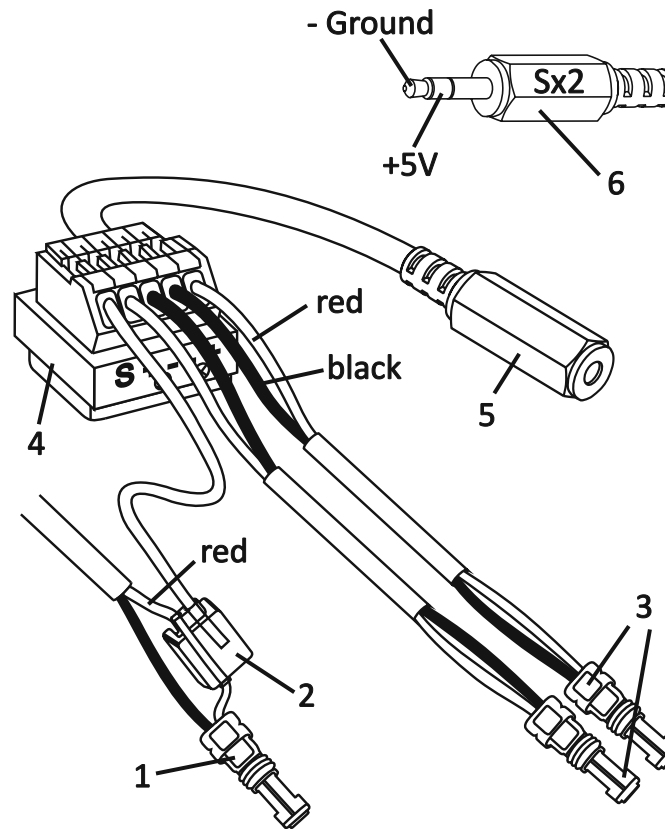

Illustration: Connection Power Switch Cable Kit:

- 1 - Plug for speed sensor
- 2 - gel blade connector
- 3 - lightning plugs for front and rear light
- 4 - Terminal block with power switching electronics
- 5 - 3.5mm stereo jack socket
- 6 - Sx2 Tuning-Dongle

5

### Installation Bosch

To get to the speed sensor, remove the stone chip cover by loosening the three Torx screws. To do so, you need the following special tools: an 8 mm 5-hex key to loosen the right crank screw, an Isis crank puller to dismount the right crank, a spidertool to release the lock ring of the spider (please note: left-hand thread!) and a TorxT20 key for the screws of the stone chip cover. Once the stone chip cover has been removed, you get access to the connecting cables and the motor unit. Now, carefully pull out the plug of the speed sensor (1) from the motor unit.

The speed sensor cable is connected to the red wire of the speed sensor. Insert the lead (without stripping) in the one-sided opening of the blade connector (2).

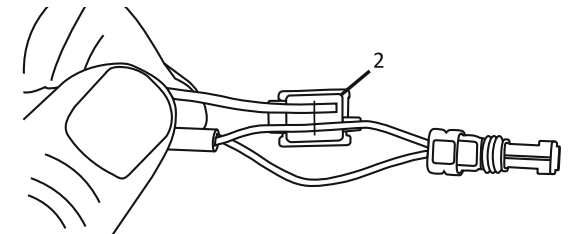

First, insert the red+ with the red lead and the black-with red/black lead between sheat and connectors (1). Afterwards, firmly press on the blade connectors (2) with your hand.

6

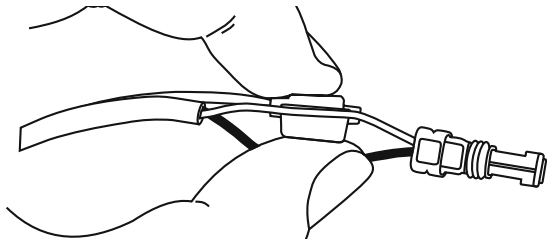

Now, compress it with pliers – at best parallel.

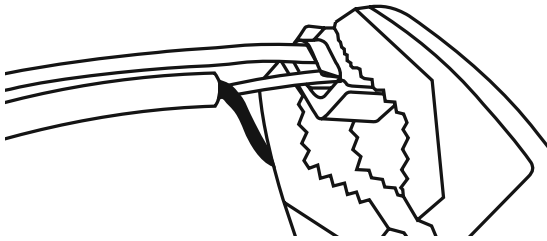

Once the terminals are compressed, the plug of the sensor (1) can be reconnected to the motor unit.

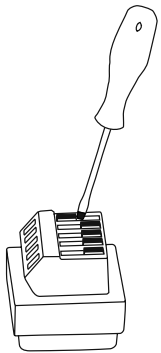

To connect cables to the terminal block, slide the white lever to the left towards the opening with a screw driver – just as illustrated in the drawing – and insert a cable without stripping into the opening. Afterwards, slide the lever back to the right. Check the cable for a tight fit. The sensor cable is linked to terminal **S** in the terminal block.

The two Bosch lightning cables are linked to the **+⊗** (red) resp. **-⊗** (black) terminals.

7

Now, the lightning plugs (3) are inserted into the designated sockets – see illustration on page 9. After the start-up and mount of the chain, slowly accelerate the pedal with your hand and check the function of the speedometer display.

If the speed is clearly visible in the display, insert the Sx2 Tuning-Dongle (6) and repeat the procedure until the changeover point has been reached and the speed is reduced by half. After that, the stone chip cover and the eBike itself can be reassembled.

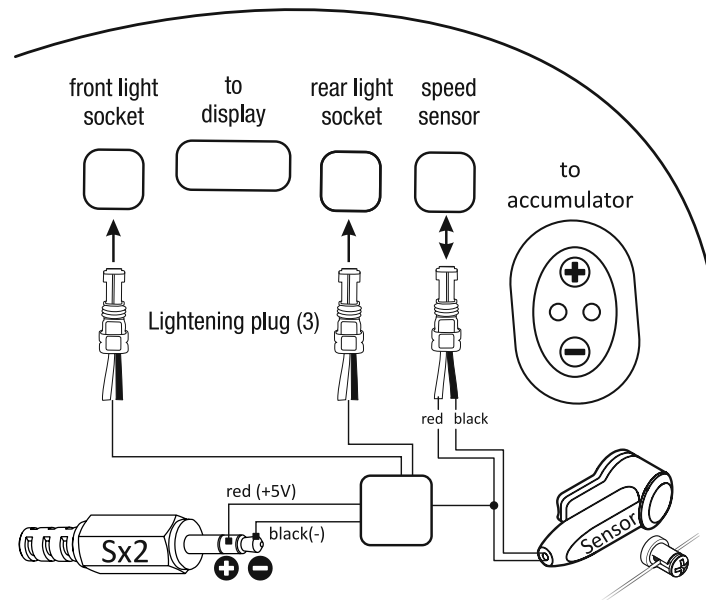

Illustration connectors Bosch Active / Performance

8

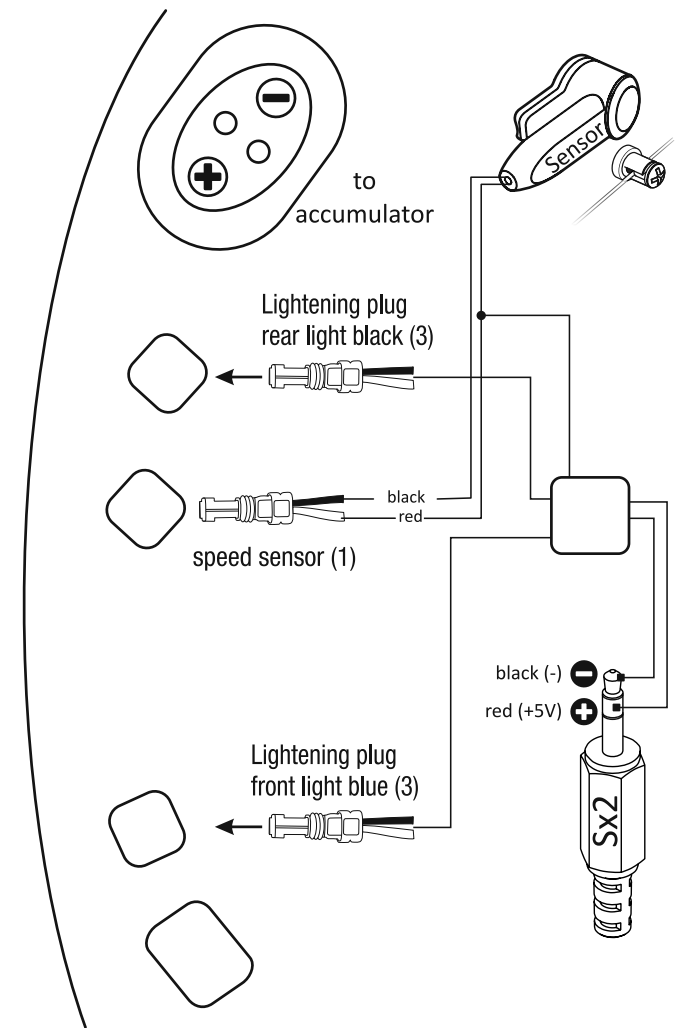

Illustration connectors Bosch Classi

9

## FAQ/Support - support.maintronic.de

In the support area of our website, you will find a manual of how to influence the changeover point as well as help and a list of frequently asked questions about the product.

## Return Consignment

The return form has to be filled in step by step, also including a detailed error description. Apart from that, the sales receipt has to be added. Our product is to be sent back to us either in a Jiffy bag or a cardboard box.

## Waste Disposal

Disposal regulations prevailing in EU countries: In accordance with the European Directive 2002/96/EG, electronic devices that are no longer useable and defective or used accumulators/batteries (European Directive 2006/66EG) must be collected separately and recycled in an environmentally sound way. Please make sure not to dispose of the Sx2 Tuning-Dongle as well as the cable kit in your household waste.

© 2019 - maintronic® GmbH reserves the right to make technical changes and product improvement without prior notice. Mistakes and typing errors reserved.

All rights reserved.

MTC maintronic GmbH  
Carl-Zeiss-Str. 10-14  
D-97424 Schweinfurt/Germany

Tel: +49 (0)9721-7766-0  
www.maintronic.de  
support@maintronic.de



## Error analysis

If the cablekit is connected but the dongle has no operation, it's possible the cablekit does not have the right connection or the voltage is not enough.

To make sure the connection is ok, the present voltage and current can be checked with a measurement device.

**Please note !!!** The magnet of the speedsensor may not exceed over the Sensor during the measurement.

## Voltage measurement:

Therefore is the best way to take a 3.5mm stereo jack with two male connectors and measure according to the below connection diagram.

Between the tip and the front ring has to be +5VDC. The tip of the jack is Ground.

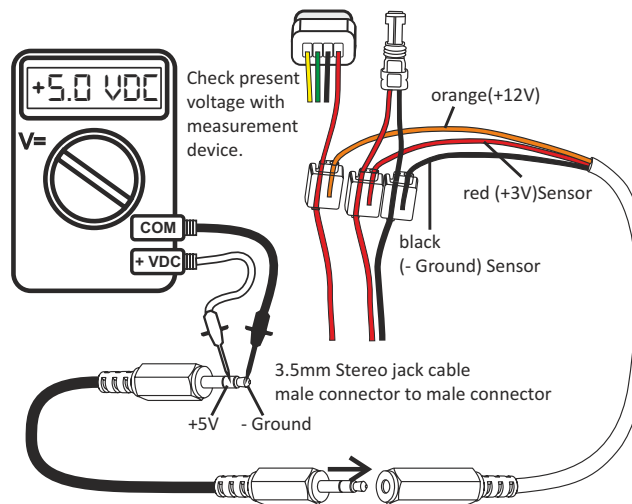

When it's plugged in with a Y-adaptor the proper working of the dongle can also be checked. Is the dongle plugged in, the voltage reduce to approximately 4.5 V.

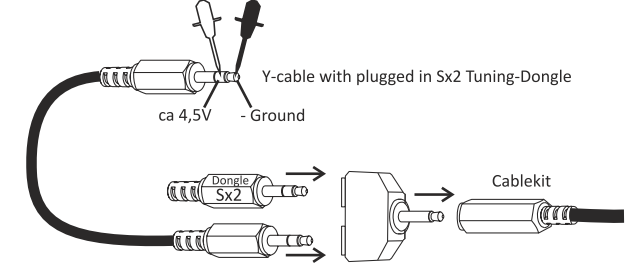

## Current measurement:

A current between 5mA and 10mA are necessary. The current is measured also between tip and front ring. The tip of the 3.5mm jack is ground.

**Important:** The measurement device has to set on the function current and the + measurement line plugged into the provided socket.

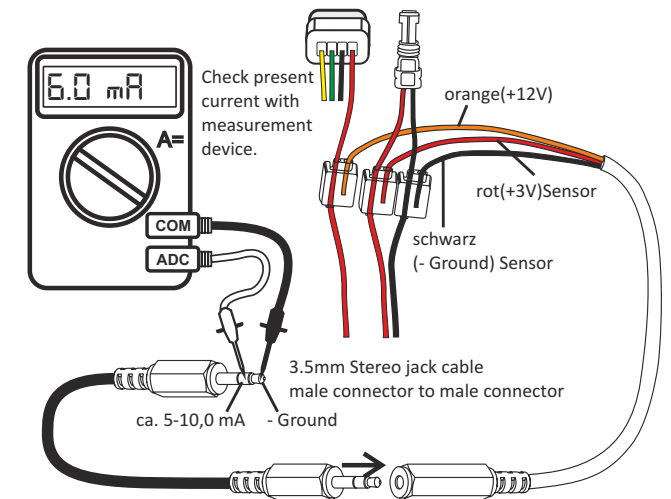

# Sx2KB-Plus Power-Switch Bosch Cablekit

## Manual with equipped light on the Bosch engine

If your eBike with Bosch engine has already light installed and the light function on the control computer is enabled, one of the two existing light cables need to be connected to our Sx2KB-Plus power switch cablekit. To use the option, the Sx2 Tuning-Dongle with the light switch on and off.

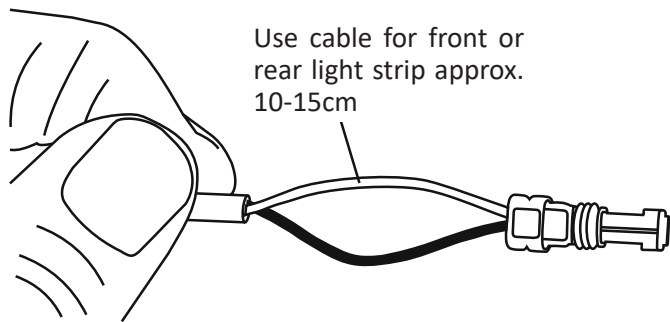

For this purpose, the insulation need to be removed about 10-15 cm behind the plug from one of the two light cables.

Please take care not to damage the single wired.

The insulation of the two wires has to be removed approx. 1 cm.

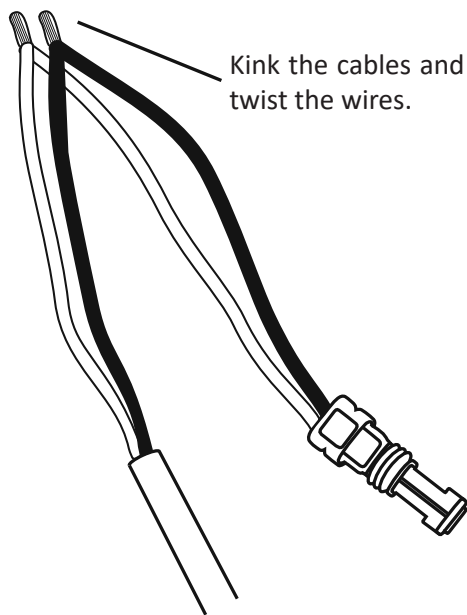

Connect the twisted wires to the terminals on the terminal block (terminal designation 1).

Please observe polarity:

red = positive pole; black = minus;

**Either the front or rear light can be connected. It is only important to connect the light cable to the input with the (1) (to the right of the speed sensor connection (S)).**

To connect cables to the terminal block, use a screwdriver to push the white lever, as shown in the picture below, to the left in the direction of the opening and insert a stripped cable into the opening. Then push the lever to the right again. Check cable for tightness.

Terminals for light cable + = red / - = black

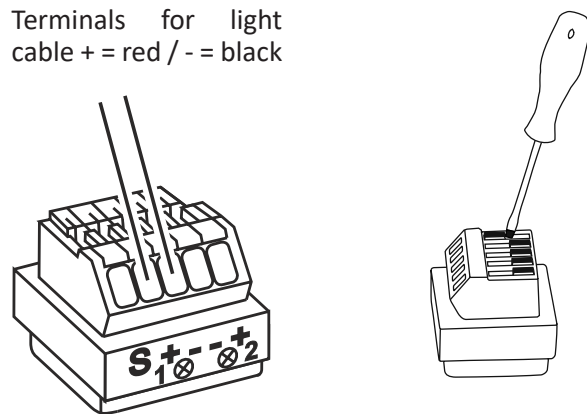

Both wires (+ red and - black) must be connected. If the cable for the light is connected to the terminal block (terminal designation 1), the speed sensor with the insulation displacement terminal can be connected according to the operating instructions.

Finally, put the plug back into the engine compartment.

